

REVISIONS					DESCRIPTION
REV.	REV. DATE	CHK. BY	CHK. DATE	ENG.	
00					

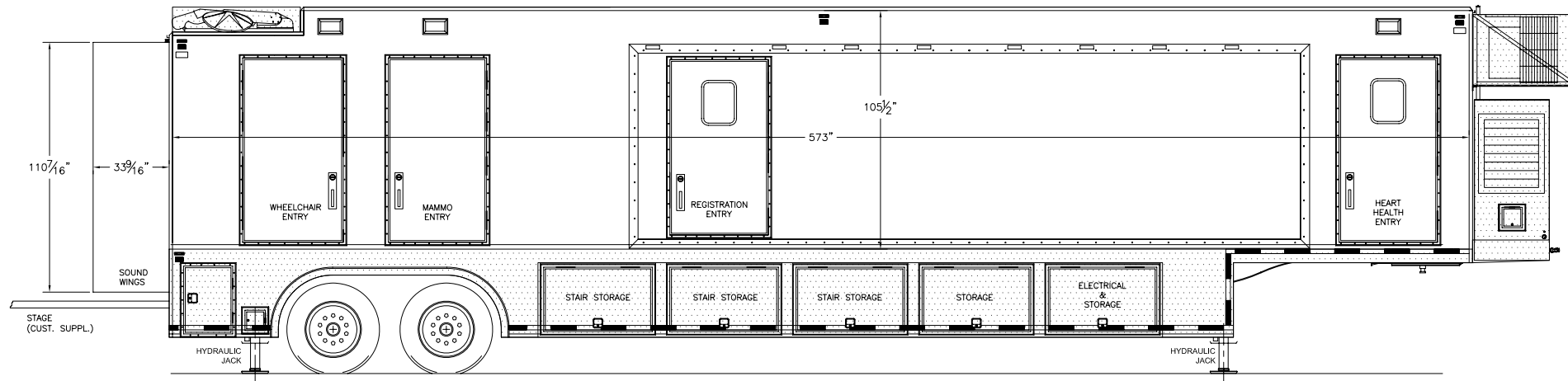

*ELEVATION VIEW  
RIGHT SIDE  
EXTERIOR*

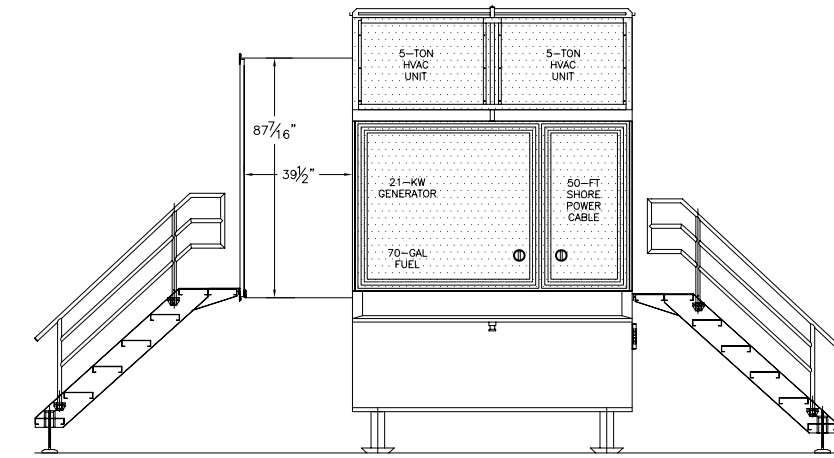

*ELEVATION VIEW  
FRONT*

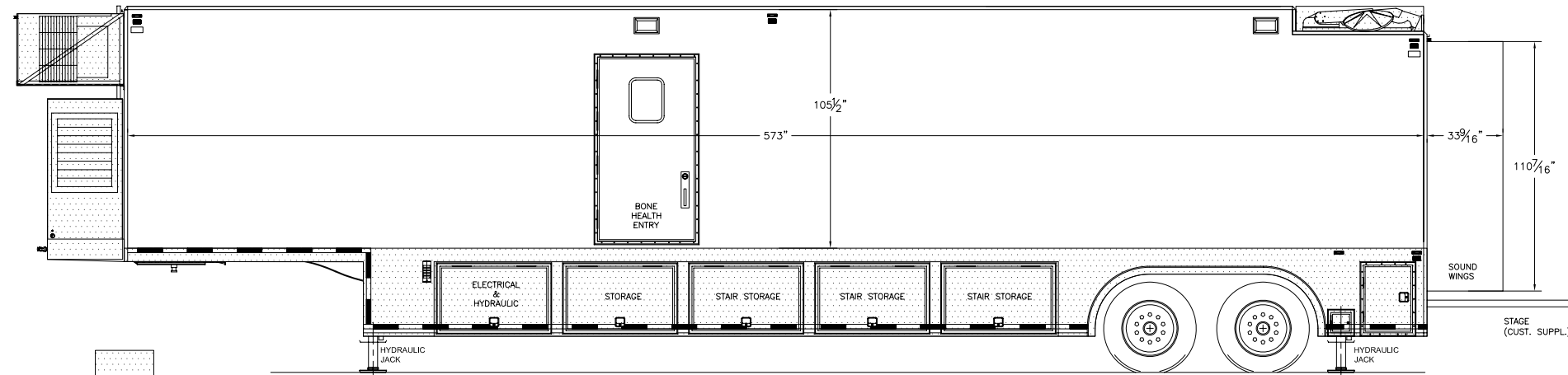

*ELEVATION VIEW  
LEFT SIDE  
EXTERIOR*

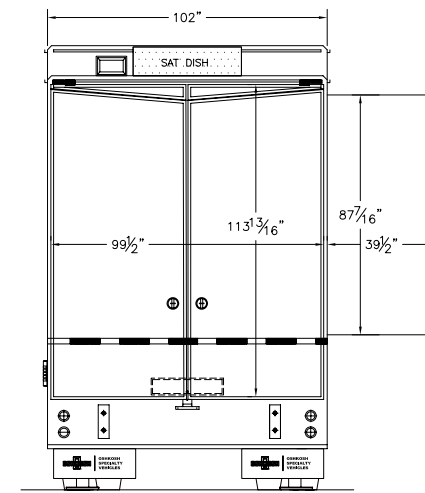

*ELEVATION VIEW  
REAR  
SOUND WINGS CLOSED*

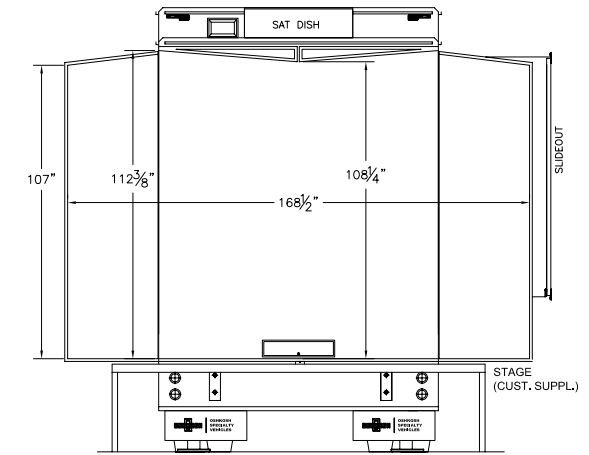

*ELEVATION VIEW  
REAR  
SOUND WINGS OPEN*

NO GRAPHICS

**NOTE: DOT REQUIRED SAFETY DECALS  
AND MEDICAL EQUIPMENT SAFETY DECALS  
MUST NOT BE COVERED BY GRAPHICS**

CUSTOMER AUTHORIZATION	
COMPANY NAME:	
NAME (PRINT):	TITLE:
SIGNATURE:	DATE:

THIS DRAWING IS PROVIDED ON A CONFIDENTIAL BASIS SUBJECT TO RETURN ON DEMAND OF OSHKOSH SPECIALTY VEHICLES ("OSHKOSH"), WHICH RETAINS ANY AND ALL RIGHTS ASSOCIATED WITH IT AND THE ARTICLE OR ARTICLES IT REPRESENTS. DISCLOSURE, REPRODUCTION OR ALTERATION OF ANY PART OF THIS DRAWING; OR MANUFACTURE, USE OR SALE OF THE ARTICLE OR ARTICLES REPRESENTED, IS PROHIBITED WITHOUT THE PRIOR WRITTEN AUTHORIZATION OF OSHKOSH. © OSHKOSH SPECIALTY VEHICLES (unpublished).

SHEET NUMBER: 1 OF 1	REFERENCE DRAWING:	TITLE: GRAPHICS LAYOUT MOVING EXPERIENCES HEALTH UNIT 8'-6" X 13'-6" X 48'-0" TRAILER	DATE: 26FEB07	SCALE: 1/2"=1'-0"
JOB#		<b>OSHKOSH</b> <b>SPECIALTY</b> <b>VEHICLES</b>	16745 S. LATHROP AVENUE HARVEY, IL, 60426 PHONE: (708) 596-5066 FAX: (708) 596-2480	CHECKED BY:  DRAWING NUMBER: 10240-A29